

Includes models

EMA1015-01
 EMA1210-01
 EMO1210-01
 EMG0615-01

ENCLOSED METAL HOSE REELS AIR/WATER - OIL - GREASE



INSTRUCTION MANUAL

INTRODUCTION

The Macnaught range of enclosed metal hose reels have been designed using the highest quality materials and are fitted with purpose specific hose and swivels. There are models available for Air/Water, Oil and Grease.

Please read and retain this instruction manual to assist you in the operation and maintenance of this quality product.

GENERAL INFORMATION

The information contained in this instruction manual will help ensure many years of trouble free operation.

Please take a few moments to read through this instruction manual before installing your new metal hose reel. If you require further assistance please contact your nearest Macnaught distributor or Authorised Macnaught Service

IMPORTANT INFORMATION



READ THIS INFORMATION CAREFULLY BEFORE USE.

Your safety is important to us. Please read and follow all safety instructions listed inside.

Some of these instructions alert you to the potential for personal injury. "Cautions" listed throughout this manual advise of potential practices or procedures which may cause damage to your equipment.

Ensure all operators have access to adequate instructions about safe operating and maintenance procedures.

- 1) Make sure the line pressure does not exceed the rated operating pressure of your model hose reel. Please refer to the specifications listed in this instruction manual.
- 2) Exposure of the skin directly to pressurised air or fluid could result in severe bodily injury.
- 3) Before carrying out any maintenance turn off and disconnect the supply line to the reel and carefully release the hose line pressure.
- 4) Use soap and water when checking for leaks.

MOUNTING INSTRUCTIONS

The reel can be wall, floor or ceiling mounted according to the pictures (Fig 1). Choose a way of mounting to avoid excessive bending of the hose against the outlet rollers.



Select a level surface to mount the reel. Mark the location holes for the bracket. Ensure that suitable fixing bolts are used and that they are secure. The bolts must each stand a torque force of minimum 3800 N.

When choosing a location it should be noted that the lifetime of the hose reel can be reduced by the influence of chemicals and strong UV or heat radiation.

Refer to Fig 2 for maximum mounting height (4m)

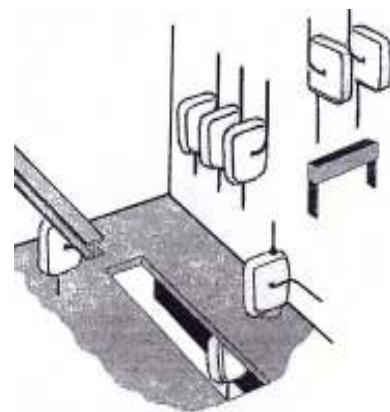

(Fig 1)

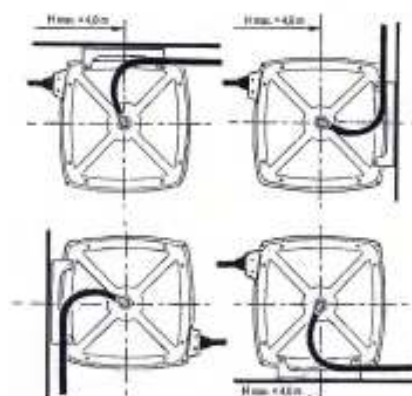

Fig 2

CONNECTION TO PIPEWORK

The reel must be connected to the pipe work system with an inlet hose length of 1m (minimum length)

Check that the hose is not twisted or strained after connection.

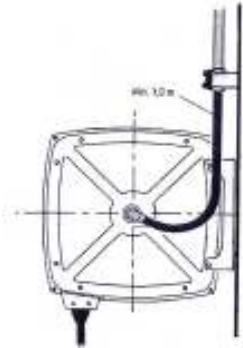

Fig 3

Note: A stop valve should be fitted on the pipe system before the hose connection.

RATCHET MECHANISM

The reel has a positive latch mechanism which will retain the hose at the desired length.

The ratchet will disengage if the hose is pulled out until the clicking stops, then slowly retract until the hose stopper rests against the reel mouth



Fig 4

CAUTION

To prevent injury or damage occurring, do not let go of the hose during rewinding.

SPRING TENSION ADJUSTMENT

INCREASE SPRING TENSION

- 1) Place an Allen key into the centre of the tension hub & remove the 4 x screws
- 2) Looking directly at the tensioning side of the reel, carefully turn the tension hub anti-clockwise .
- 3) After increasing to the required tension carefully replace the 4 x screws, then remove the Allen key.

DECREASE SPRING TENSION

- 1) Place an Allen key into the centre of the tension hub & remove the 4 x screws.

- 2) Carefully allow the tension hub to unwind until the correct tension is achieved.

- 3) Carefully replace the 4 x screws, then remove the Allen key.

MAINTENANCE

It is recommended that the following checks are carried out at least once a year.

CAUTION

Turn off and disconnect the supply line before carrying out any maintenance.

- 1) Check that the spring recoils properly.
- 2) Check for any signs of leakage from the swivel, hose assembly or connections.
- 3) Check that the hose is not damaged. Replace hose assembly if found to be damaged.
- 4) Check that the latch mechanism is functioning correctly.
- 5) Check the reel is fixed to the wall or ceiling securely and the fixing bolts are tight.

HOSE REPLACEMENT

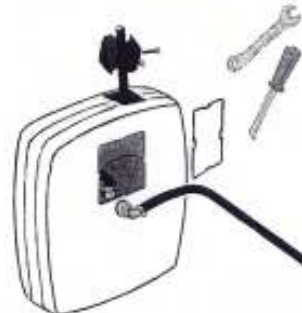

Fig 5

CAUTION

Turn off and disconnect the supply line before removing reel from the installation.

NOTE: Please ensure the correct hose is used when replacing hose assembly. (Refer to the hose specifications listed in this instruction manual)

- 1) Place the reel on a suitable work bench
- 2) Remove the spring tension. (Refer to Decrease spring tension)
- 3) Remove the plastic cover. (Refer Fig 5)
- 4) Pull the hose out of the reel. Using a suitable size spanner, unscrew and remove the hose from the nipple. The nipple can be accessed through the window on the side of the reel. (Refer Fig 5)
- 5) Remove the hose from the reel

6) Feed the new hose through the reel outlet and attach it to the nipple located inside the drum assembly. Access is through the window on the side of the reel. (Refer Fig 5)

7) Replace the plastic cover

8) Fit the hose stopper close to the end of the hose.

9) Retract the hose into the reel by turning the tension hub with an Allen key. Once the hose has been fully recoiled into the reel, add a further 3 full tension turns for a 3/8" hose or a further 6 full tension turns for a 1/2" hose.

10) Re-connect inlet hose (min length 1m)

11) Re-fit reel to the installation turn on the supply and check connections for any leaks.

REPLACE SWIVEL / SWIVEL SEALS

- 1) Carefully remove the old seal .
(Make sure you do not score or mark the swivel body)
- 2) Carefully fit the new seal
- 3) Lightly grease the swivel shaft before re-assembly.

SPRING REPLACEMENT



WARNING

NOTE: The main spring is a non replaceable part. If damaged or broken a new reel is required.

SPARE PARTS DIAGRAM

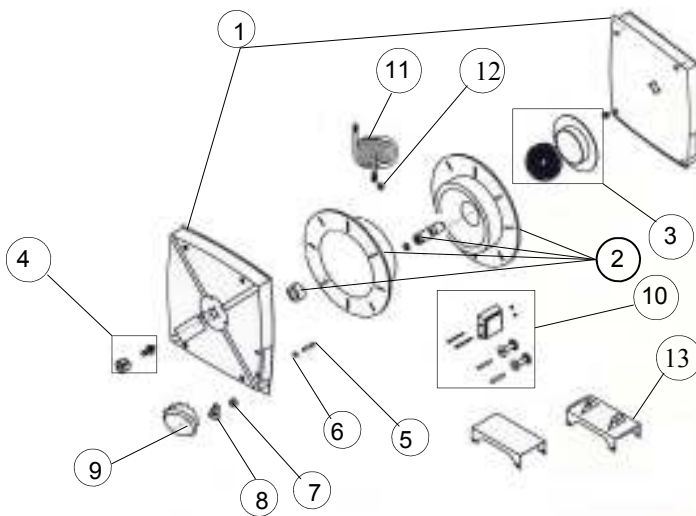

SPARE PARTS LIST

New parts list			
Item No	Part or set	No Off	Description
1	n/a	1	Side Cover Set
2	n/a	1	Drum Assembly
3	n/a	1	Spring and Cover Set (Air / Water) 3/8"
3	n/a	1	Spring and Cover Set (Air / Water) 1/2"
3	n/a	1	Spring and Cover Set (Oil)
3	n/a	1	Spring and Cover Set (Grease)
4	EM31s	1	Swivel Assembly (Air / Water / Oil) 3/8"
4	EM30s	1	Swivel Assembly (Air / Water / Oil) 1/2"
4	EM29s	1	Swivel Assembly (Grease)
4*	EM28s - not show n	1	Swivel Seal Set (Air / Water / Oil) 3/8"
4*	EM27s - not show n	1	Swivel Seal Set (Air / Water / Oil) 1/2"
4*	EM26s - not show n	1	Swivel Seal Set (Grease)
5		1	Latch Stopper Pin
6		1	Latch Spring
7	EM25s	1	Latch Bush
8		1	Latch Plate
9	n/a	1	Latch Ratchet
10	EM24s	1	Roller Guide Set
11	RH20s	1	Hose Assembly (Air / Water /) 3/8" x 15m
11	RH38s	1	Hose Assembly (Air / Water /) 1/2" x 10m
11	RH81s	1	Hose Assembly (Oil) 1/2" x 10m
11	RH45s	1	Hose Assembly (Grease) 6mm x 10m
12	Z10s	1	Hose Stopper (Air / Water/ Oil) 3/8"
12	Z40s	1	Hose Stopper (Air / Water/ Oil) 1/2"
12	Z10s	1	Hose Stopper (Grease) 6mm
13	EM36s	1	Reel Bracket

TROUBLE SHOOTING GUIDE

TROUBLE	CAUSE	REMEDY
Hose will not fully retract	A) Outlet nozzle, gun or tool is too heavy	A) Add spring tension. See " Adjust Spring Tension"
	B) Spring is fatigued	B) Add spring tension. See " Adjust Spring Tension" B) Spring is non-replaceable -replace reel if the spring is broken or damaged
	C) Replacement hose is too long	C) Fit correct length hose (Refer Hose to specifications)
Hose will not retract at all	A) Spring has broken or has lost all tension	A) Replace reel if the spring is broken or damaged
Reel will not latch	A) Incorrect operation	A) Reel latches on first, second or third "click". After the third click the reel automatically rewinds
	B) Latch assembly is worn.	B) Replace the latch assembly
Fluid leaks from the swivel	A) Swivel seals are worn	A) Replace swivel seals. See " Replacement of Swivel Seals".

TECHNICAL SPECIFICATIONS

SPECIFICATIONS

Model	Description	Hose Specifications			Reel colour	Reel Inlet Thread Size	Hose Outlet	Weight
		I.D	Length	Max Working Pressure				
EMA1015	AIR / WATER	3/8" (10mm)	15m	430 psi	Blue	3/8" BSP	3/8" BSP	17/20kg
EMA1210	AIR / WATER	1/2" (12.5mm)	10m	430 psi	Blue	1/2" BSP	1/2" BSP	17/20 kg
EMO1210	OIL	1/2" (12.5mm)	10m	2000 PSI	Blue	1/2" BSP	1/2" BSP	17/20 kg
EMG0615	GREASE	1/4" (6mm)	15m	5000 PSI	Blue	1/4" BSP	1/4" BSP	17/20 kg



Macnaught Pty Limited
ABN 66 000 075 785

41-49 Henderson Street
Turrella NSW 2205 Sydney Australia
Postal Address PO Box 90
Ancillie NSW 2205 Sydney Australia

T: +61 2 9567 0401
F: +61 2 9567 7773
W: www.macnaught.com.au

Note:

This product should be disposed of according to all applicable local and national government environment regulations and guidelines.



For Warranty Terms and Conditions see macnaught.com.au
For a list of Australian Service Centres see macnaught.com.au