

GT-01-BD BIO-DIESEL RAPIDFLO™ ROTARY FUEL PUMP INSTRUCTION MANUAL



Introduction

Thank you for purchasing a Macnaught GT-01-BD Bio-Diesel RAPIDFLO™ Rotary Hand Fuel Pump.

Please read and retain this instruction sheet to assist you in the operation and maintenance of this quality product. Take particular note of all warnings and safety messages.

Description

Your Macnaught GT-01-BD Rapid-Flo Fuel Pump is an impeller type pump incorporating a gearbox for high output and easy operation. Materials used in the construction of this pump include Aluminium, Carbon Steel, Nitrile rubber and Viton rubber.

The features of your pump include long life, anti-static rubber hose with support springs, weather protected nozzle holder, nozzle and lockable handle. The locking device in the handle accepts 6mm diameter shackle padlock (not supplied).

An optional Model VA Fuel Filter Kit is available from your Macnaught dealer. This kit contains the filter assembly and fittings required to connect the filter to your pump. It features a 10-micron fast flow filter element, (Not suitable for AV Gas)

Important

This pump is designed for use only with Bio-Diesel, as well as leaded/unleaded petrol, diesel, kerosene and light mineral oils to SAE 30. Do not use this pump for dispensing fluids other than those for which it was designed. To do so may damage pump seals and/or other components and will void the warranty.

When using this pump in reverse care must be taken to prevent contaminants entering pump.

For pumping AV gas contact local aviation authorities for the correct aircraft refuel procedures.

CAUTION

Handling flammable liquids is hazardous. There is the potential for an explosion and/or fire. Your personal safety, and the safety of others are at risk. It is your responsibility to know and follow all safety precautions when handling flammable liquids & ensure all equipment operators have adequate instructions concerning safe procedures.

Follow all recommended safety precautions when handling flammable liquids such as petrol.



Pumping should only occur in well ventilated areas. Never fill containers in confined areas, e.g. inside a vehicle. Do not operate pump in areas where vapours can accumulate.

IMPORTANT

Your Macnaught GT-01-BD RAPIDFLO™ is supplied with an anti-static hose to reduce the opportunity for static charge to accumulate. Always use Macnaught anti-static hose when pumping petrol & other flammable liquids. .

Fuel storage tanks and drums should be metal and grounded to earth. Ensure the floor or ground where fuel is stored or dispensed is and remains electrical conductive.

This pump is fitted with a 180-micron mesh strainer on the suction tube side of the pump to prevent foreign matter damaging the pump. If pumping in reverse, fit a strainer to the Hose Nozzle.

ASSEMBLY

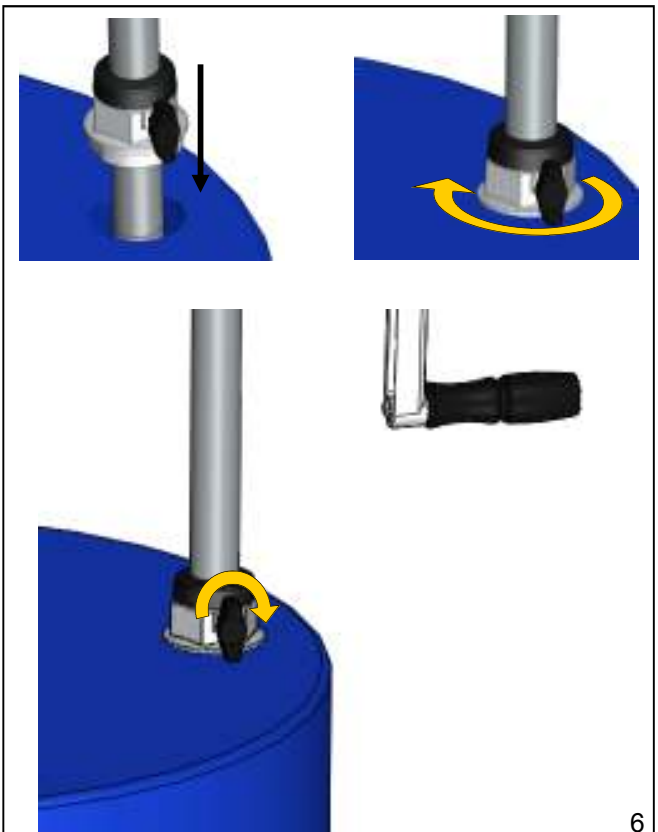
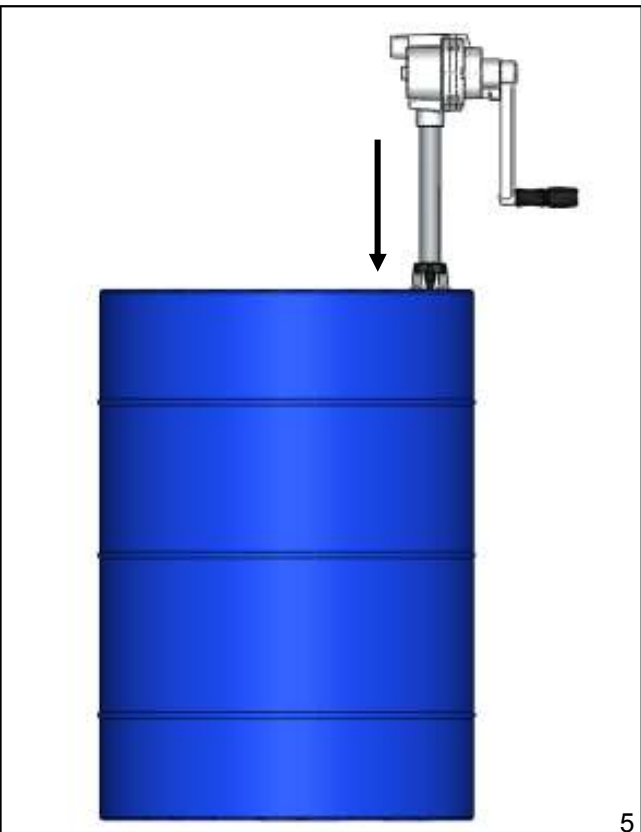
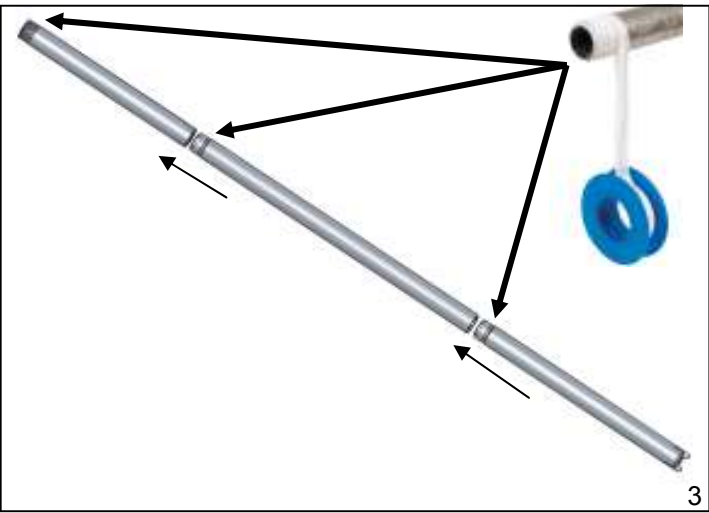
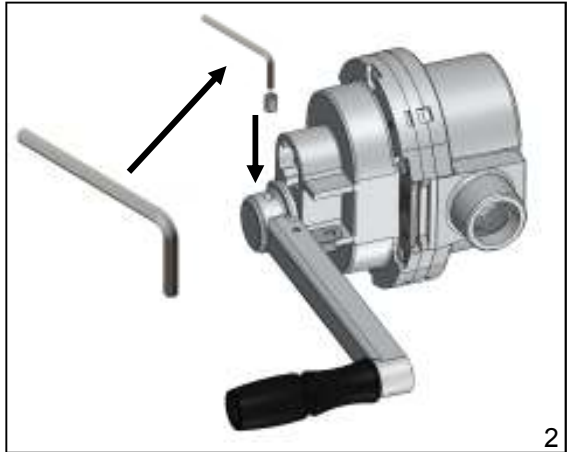
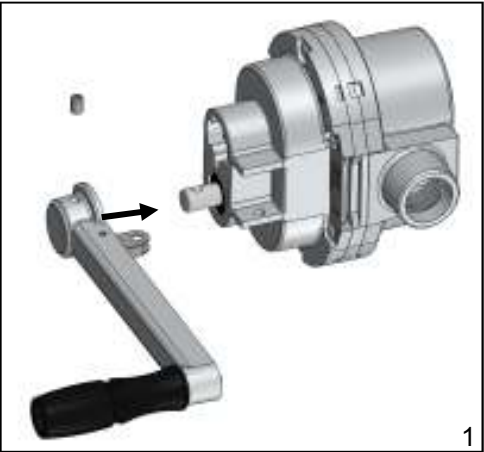

ASSEMBLY



Note:
Important Hose to pump and
nozzle assembly procedure

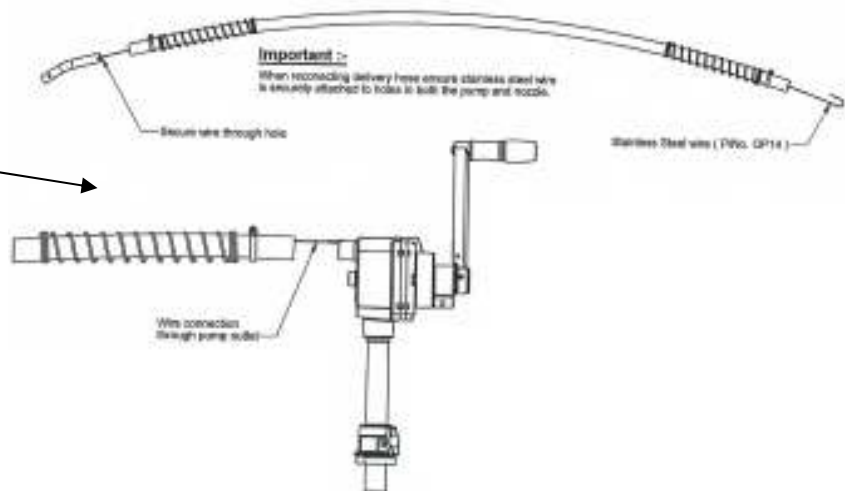

OPERATION



Turn handle quickly to prime the pump.
Slow down once the pump is primed.

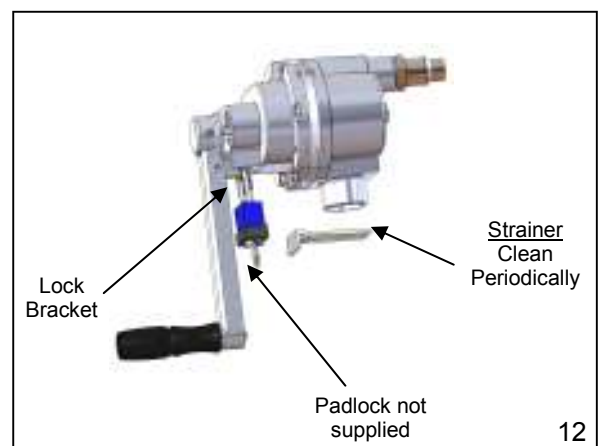
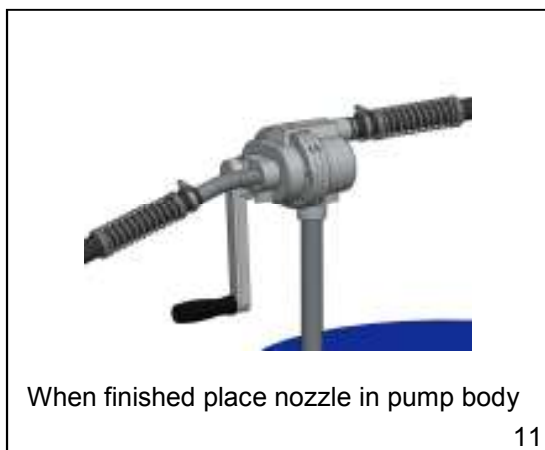

OPTIONAL VA FUEL FILTER

The VA Fuel Filter is particularly recommended for diesel fuel users. The Filter Kit is complete with all fittings to enable fast, simple installation and features a 10-micron filter element & see through bowl with drain cock.



CAUTION

If carrying out maintenance on this pump, for your own protection, thoroughly drain the pump and hose before disassembly. Clean flammable liquids from components as they are removed from the pump. Follow precautions when handling flammable liquids

TROUBLE SHOOTING GUIDE

TROUBLE	CAUSE	REMEDY	
Pump feels hard to turn, or is hard to prime.	Blocked strainer	Clean strainer - see page 3 (fig 12)	
		a) Loosen the 2 socket head screws holding strainer retainer plate in place	
		b) Swing retainer plate away and remove strainer.	
		c) Clean and re-fit strainer.	
Pump is hard to prime.	Air leaking past suction tube threads.	Seal suction tube threads:	
		a) Apply Teflon tape or similar thread sealant to both male threads on suction tube.	
		b) Tighten lower tube to top tube and top tube to Pump body	
Pump leaks at cover or drive shaft.	Worn or damaged seals	Replace seals	
		a) Remove 6 screws	
		b) Use a pin punch to remove 2 parallel pins	
		c) Remove cover assy.	
		d) Gently tap bearing housing to break seal to body and remove bearing housing assy.	
		e) Remove screws gears and impellers	
		f) Push out old bearings and seals	
		g) Reassemble using new bearings and seals.	
		IMPORTANT	
		Apply a very thin film of a Gasket compound such as "Form-a-Gasket", between gear base & pump cover. Too much will jam impellers. Align the timing marks on the Gears when assembling to shafts.	
Apply a very thin film of a Gasket compound such as "Form-A-Gasket" or similar between gear base & pump cover			
Handle will not turn.	Foreign matter jamming impellers	Disassemble pump as in "Replace Seals" above. Clean thoroughly. Smooth off any high spots with fine emery paper. Reassemble as above.	

PARTS DIAGRAM

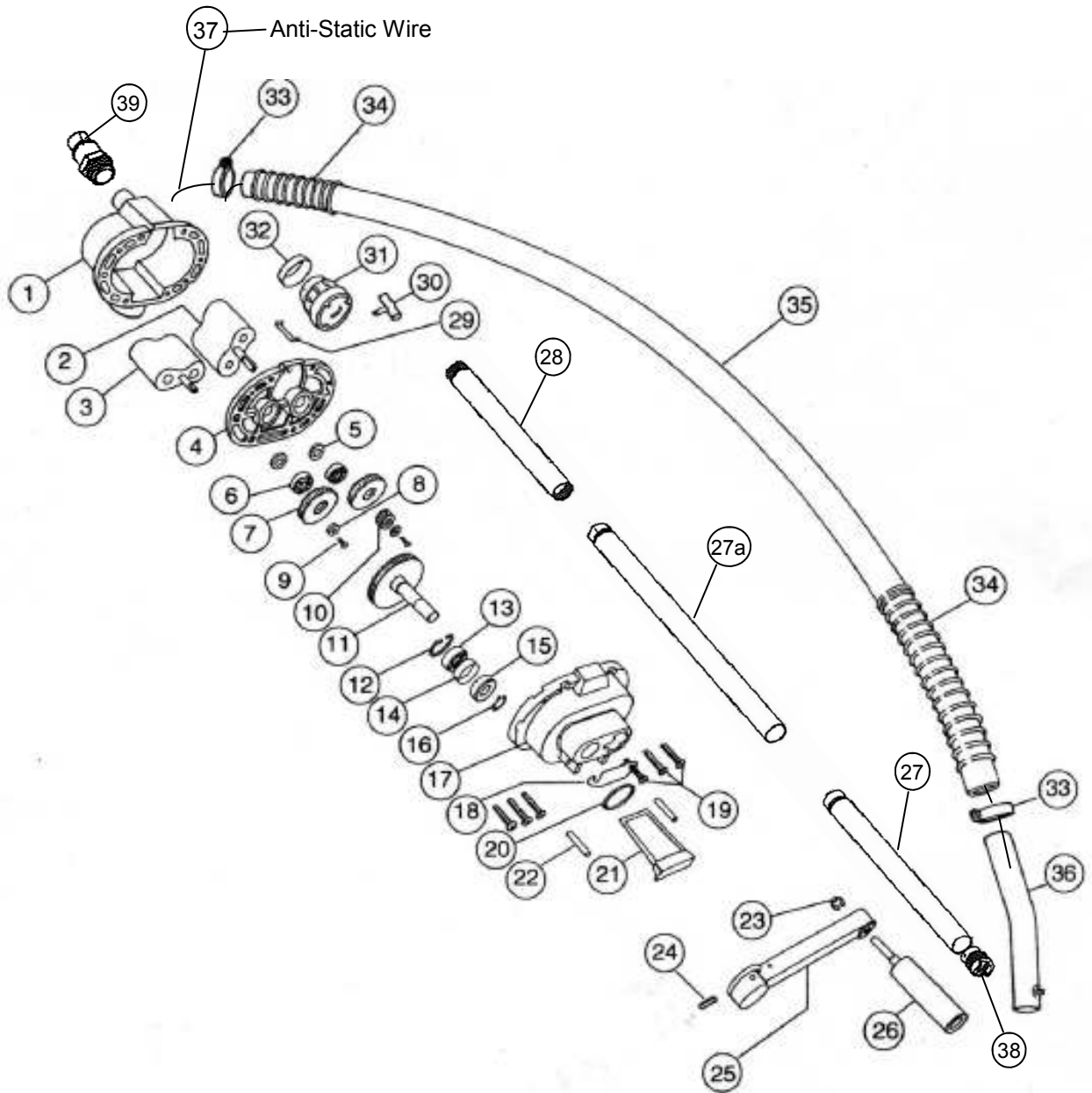

Parts List

		Order for replacement			
Item No.	No. off	Part or Set	Kit Ref.	Part Name	
		BD-1K (Kit A)			
1	1	GP-1K		Body	
2	1	n/a		Impellor - Long Shaft	
3	1	n/a		Impellor - Short Shaft	
4	1	n/a		Bearing Housing	
5	2		A	Seal	
6	2		A	Bearing	
7	2			Impellor Gear	
8	2			Retainer Washer	
9	2		GM23s (incl GM12)	A	Csk Hd Socket Screw
10	1				Pinion
11	1				Drive Gear Assy
12	1			A	Circlip
13	1			A	Bearing
14	1			A	Spacer
15	1			A	Bearing
16	1			A	Circlip
17	1	n/a		Cover	
18	1		A	Retainer Plate	
19	6		GM5s		Cover Screw
20	1			A	O'Ring (Viton) BS123V
21	1			A	Strainer
22	2		A	Parallel Pin	
23	1			Circlip	
24	1		GM4s		Grub Screw
25	1				Crank Casting
26	1				Grip
27	1			Lower Tube	
27a	1				Intermediate Tube
28	1				Upper Tube
29	1			Locking Plate	
30	1		GR34s	ST005As	Clamp Screw
31	1				Bung Adaptor
32	1			A	Cover
33	2				Hose Clamp
34	2	GP13S		Hose Spring	
35	1			Hose	
36	1			Nozzle	
37	1			Anti-Static Wire	
38	1	AG54s		Footvalve set	
39	1			Hose Tail	

Notes:

SPECIFICATIONS

Flow Rate:	Up to 100 l/min
Output per Revolution:	0.8 l/rev approx.
Maximum Viscosity:	SAE 30 at 20°C
Maximum Suction Head:	2m (7')
Maximum Discharge:	4m (14')
Mass:	6.5kg approx



Macnaught Pty Limited
ABN 66 000 075 785

41-49 Henderson Street
Turrella NSW 2205 Sydney Australia
Postal Address PO Box 90
Ardcliffe NSW 2206 Sydney Australia

T: +61 2 9567 0401
F: +61 2 9597 7773
W: www.macnaught.com.au

Note:

This product should be disposed of according to all applicable local and national government environment regulations and guidelines.



For Warranty Terms and Conditions see macnaught.com.au